



COOL DOG™
WATER FOUNTAINS.COM

DOGGIE DEMAND™

Motion-Activated Dog Water Spout Drinking Fountain

DL-1000-DD

Dog Water Spout

DL-1000-DD-DWC

Dog Water Spout and Hose Bib

STANDARD FEATURES

- 100 mesh inlet strainer
- Pushbutton requiring less than 5 pounds for activation
- Stainless Steel, anti-rotation, non-squirt bubbler for pet fountain
- Vandal resistant stainless steel access panel
- 18 gage, 304 stainless steel basin
- Heavy duty, 304 stainless steel polished to a satin finish

This premiere outdoor water spout is intended to be mounted onto a concrete pad using the hardware provided. Fixture includes both sensor and push-button operation for pet fountain by others.

VALVE SPECIFICATIONS

Minimum/Maximum Pressure 30 to 100 psi.

ONE YEAR WARRANTY



**FRESH WATER
IS A MUST
AT THE
DOG PARK!**





COLOR SELECTION

Premium heavy-duty outdoor commercial powder-coated stainless steel.

BLUE



RED



YELLOW

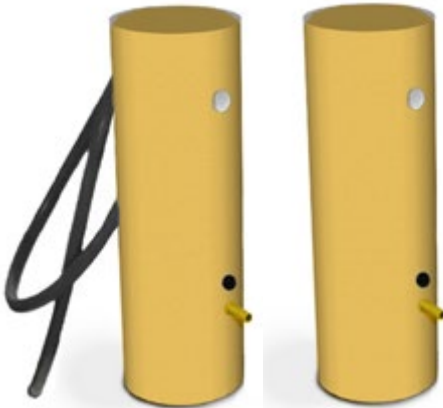

SILVER



GREEN



Hoses are great for parks with artificial turf or parks with doggie pools in the summer time!

PRIOR TO INSTALLATION

1. Read all installation instructions carefully, before proceeding.
2. Carefully remove fixture from packaging, preventing scratching or damage.
3. **Unit is provided with six AA alkaline batteries.**
4. Provide mounting surface, sufficient to support the fixture and loads on the fixture.
5. Provide rough-ins as shown on the roughing-in and dimensional drawing, including water supply, drain pipe and gravel drain well. (See rough-in details)
6. Completely flush water supply lines of all foreign debris, before connecting to the fixture.

INSTALLATION (see drainage & mounting roughing-in)

1. Locate the unit over rough-ins on mounting pad, mark mounting holes in base flange.
2. Tilt the unit down on its side, next to the mounting location. Install ½" mounting anchors (by others). Optional -IAP (in-ground anchor plate) which is cast into the concrete, is available.
3. Make up 1-1/4" OD drain tube into the open ended DWV drain tube (by others). Connect the ½" male NPT fitting to a potable water supply. Then tilt the unit into place, making sure that the tubing is not pinched or kinked. Secure the base flange to the mounting pad.
4. Connect the battery pack to matching battery wire terminals. When connected the unit is active.
5. Test for leaks and proper operation, and then install the access panel.

START UP

Air within the bowl system or the structure supply piping will cause an irregular spout outlet stream until purged out by incoming water. Press and hold pushbutton until steady water stream is achieved.



▼ DL-1000-DD

GENERAL NOTES

1. All dimensions are in inches.
2. Stop valve not provided.

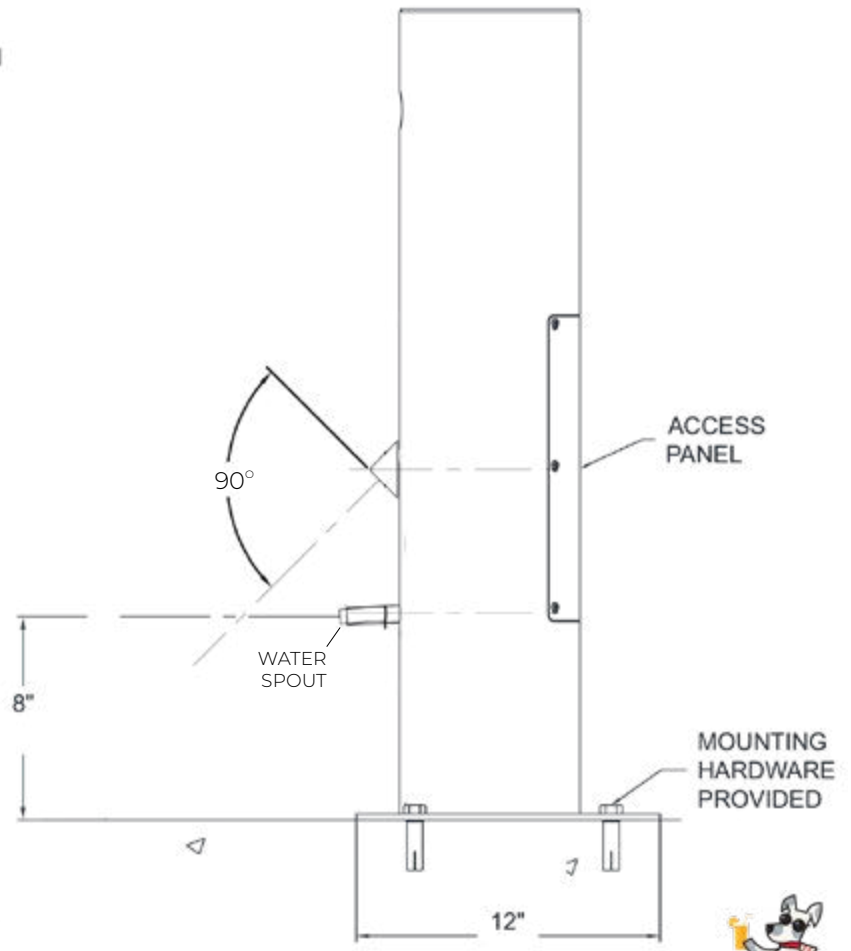
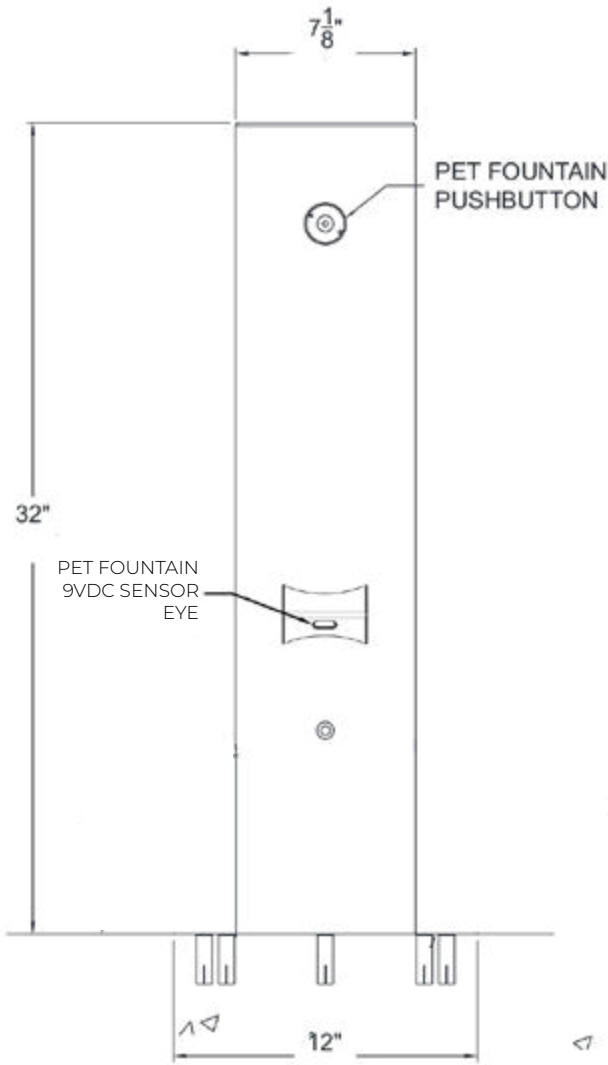
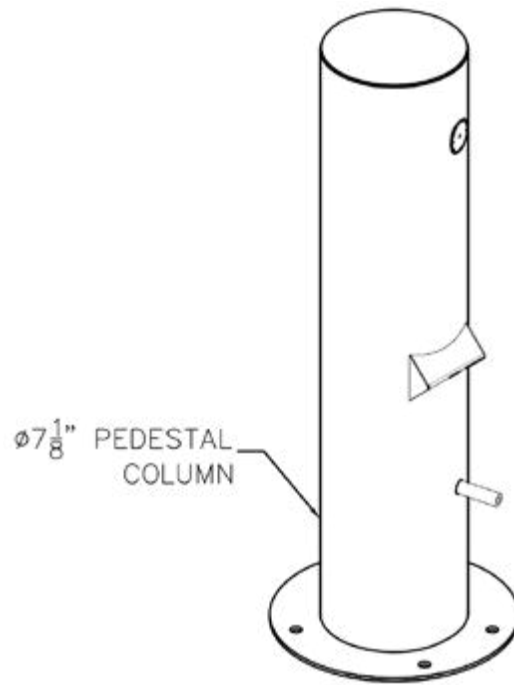
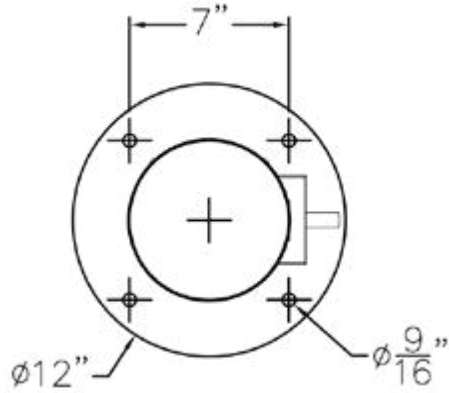

COOL DOG
WATER FOUNTAINS.COM

DL-1000-DD-DWC

GENERAL NOTES

1. All dimensions are in inches.
2. Stop valve not provided.

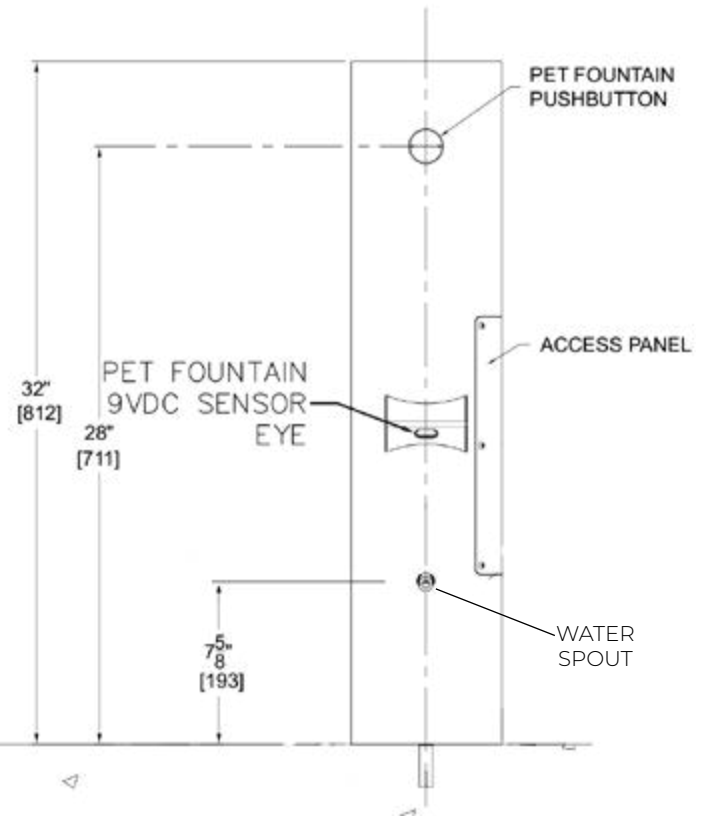
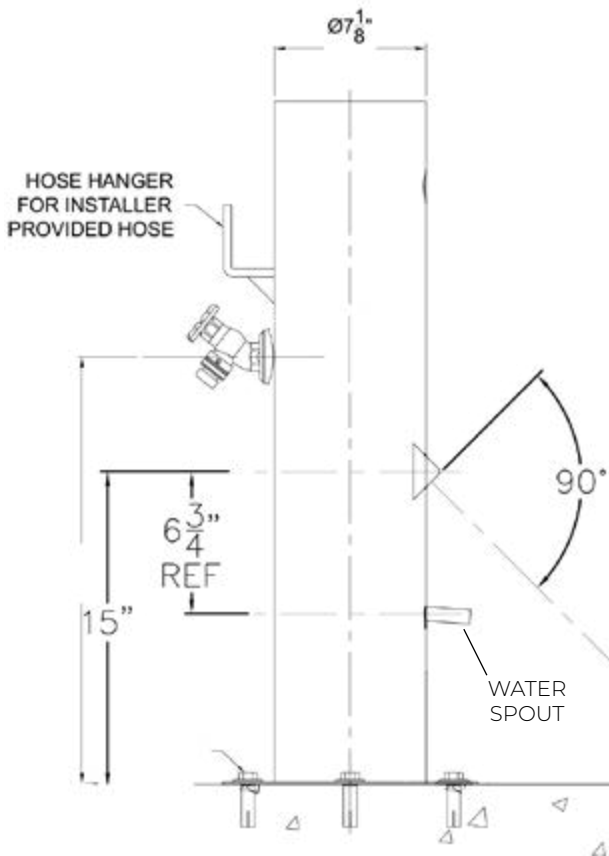
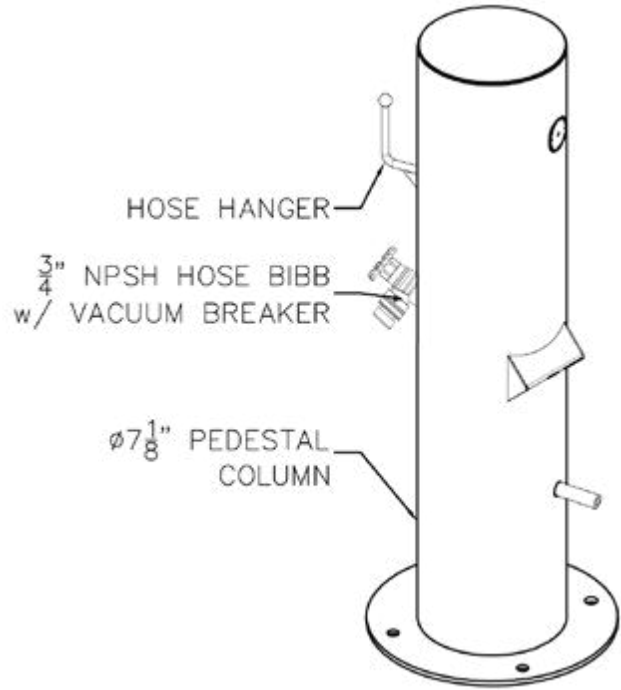
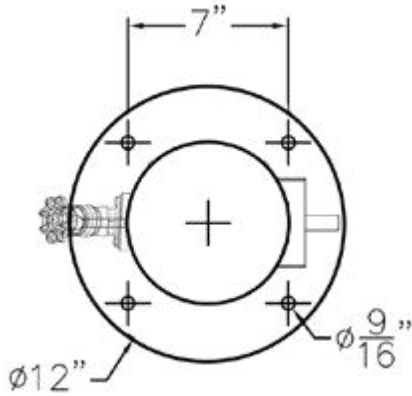

TROUBLESHOOTING

1. Restricted or No Water Flow

- a. Ensure Water Supply service stop valve is fully open.
- b. Verify minimum 20 psi supply line flow pressure.
- c. Check for twist or kinks in spout tubing.
- d. Check the water inlet “Y” strainer. Sediment from the main supply can get trapped in the screen along with installation materials such as pipe dope and flux. The screen should be cleaned and checked on a regular basis and replace if needed.
- e. Flow control in solenoid valve outlet elbow clogged remove & clean.

SENSOR TROUBLESHOOTING

1. If Light Within Sensor Does Not Flash Once When User Is Within Range

- a. Verify 9VDC output of battery pack.
- b. Replace defective batteries.
- c. Sensor in “Security Mode” after 30 seconds of constant detection. Remove source of detection and wait 30 second before checking.
- d. Sensor is picking up a highly reflective surface. Eliminate cause of reflection and wait 30 seconds before checking.

2. If Light Within Sensor Lens Flashes Once When The User Is Within Range

- a. Repair bad connection from sensor to solenoid.
- b. There is debris or scale in the solenoid assembly. Remove solenoid, pull out plunger and spring. Clean with scale remover solution.
- c. There is debris or scale in center or two holes in convolution of the water diaphragm. Remove and clean.

CLEANING AND MAINTENANCE

1. To remove water spots or rust spots, stainless steel cleaner/polish on a cloth is recommended.
2. If there are stubborn spots or if you wish to treat a scratch, synthetic abrasive general purpose pads such as Scotch Brite are recommended.
3. Apply stainless steel cleaner/polish to the synthetic abrasive pads and carefully rub the panel with the grain.
4. DO NOT use harsh chemicals, abrasive or petroleum based cleaners. Use of these will void the warranty. DO NOT use abrasives on powder coated units.
5. Stainless steel should be kept clean at all times. If a coating of stainless steel cleaner/polish is maintained, stainless steel surfaces will retain their new, clean & polished appearance indefinitely.
6. Periodically remove access panel of cooler and clean out inline “Y” strainer

BATTERY REPLACEMENT

1. Unlock and swing open bowl filler door and remove battery pack from placed location. Do not disconnect the wires from the battery pack unless necessary.
2. Replace the six alkaline AA batteries while observing polarity.
3. Return the battery pack back to mounted location and test for proper operation. Then close bowl filler door and lock.

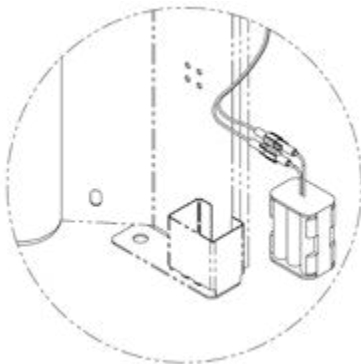

CONCRETE PAD

Water fountain must be secured to a concrete pad no smaller than what is recommended below (see images for dimensions (*not to scale*)).

DL-1000-DD-DWC

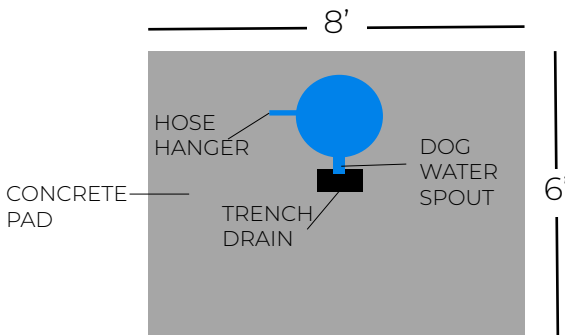

DL-1000-DD

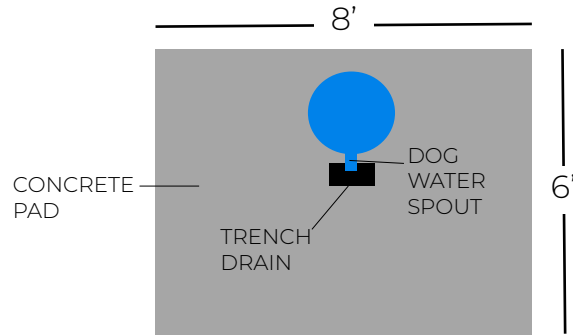

OPTIONAL TRENCH DRAIN GRATES (not included) Recommended Materials



- Light duty, 3,500 lbs – 70 psi
- For pedestrian, wheel chair and bicycle traffic
- Best not to use stainless steel.
- Trench drains will keep pad dry in areas where water can collect.

Example

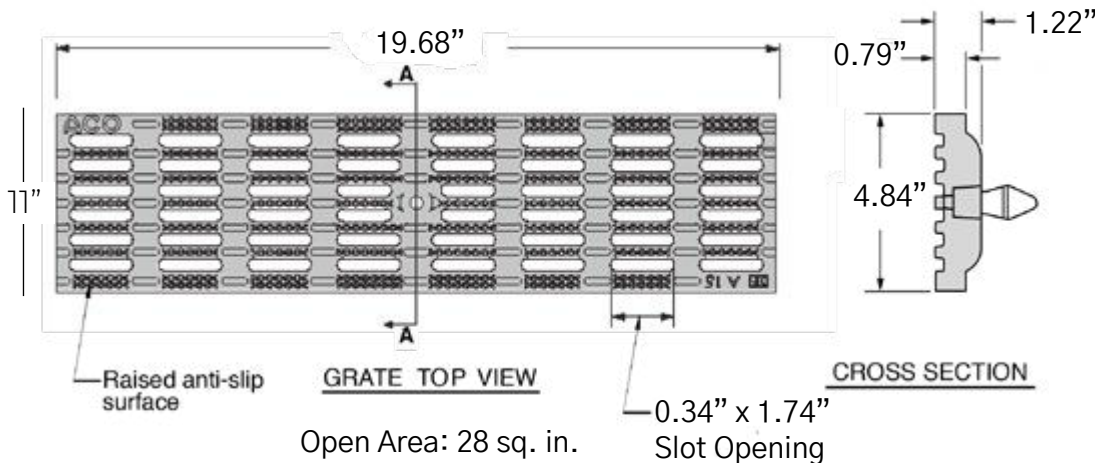
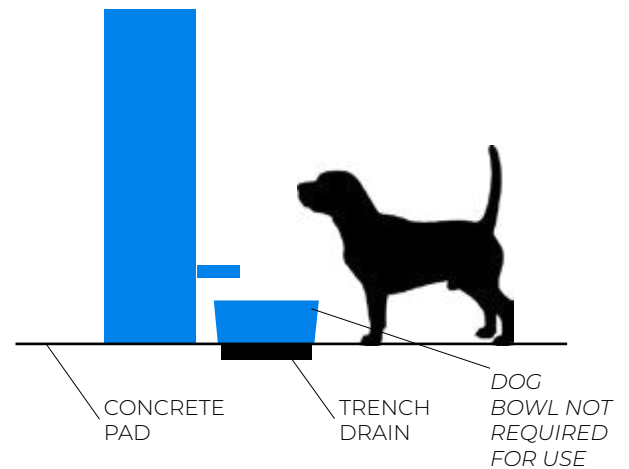

COOL DOG
WATER FOUNTAINS.COM

**ALL SERVICE TO BE PERFORMED BY AN AUTHORIZED SERVICE PERSON
IMPORTANT! INSTALLER PLEASE NOTE.**

THE GROUNDING OF ELECTRICAL EQUIPMENT SUCH AS TELEPHONE, COMPUTERS, ETC. TO WATER LINES IS A COMMON PROCEDURE. THIS GROUNDING MAY BE IN THE BUILDING OR MAY OCCUR AWAY FROM THE BUILDING. THIS GROUNDING CAN CAUSE ELECTRICAL FEEDBACK INTO A FOUNTAIN, CREATING AN ELECTROLYSIS WHICH CAUSES A METALLIC TASTE OR AN INCREASE IN THE METAL CONTENT OF THE WATER. THIS CONDITION IS AVOIDABLE BY USING THE PROPER MATERIALS AS INDICATED. ANY DRAIN FITTINGS PROVIDED BY THE INSTALLER SHOULD BE MADE OF PLASTIC TO ELECTRICALLY ISOLATE THE FOUNTAIN FROM THE BUILDING PLUMBING SYSTEM.

1. This fountain is to be mounted on a smooth, flat, finished surface with adequate support structure. NOTE: Mounting structure must be capable of supporting 300 lb. load on fountain.
2. Refer to rough-in for plumbing.
3. Install shut-off valve on water supply. (Valve not furnished)
4. Locate and install fountain using 3/8" minimum fasteners. (Fasteners not furnished)
5. Connect water supply and fountain drain. Connect drain waste "Tee" to fountain drain tubes. Connect outlet of "Tee" to drainage system. Water connection and drain must comply with local codes.
6. Turn on water supply and check all connections for leaks.

CAUTION: This fountain is rated for inlet water pressure of 20-105 PSI. A pressure reducing regulator should be used if the inlet water supply exceeds 105 PSI. Any damage caused by reason of connecting this product to supply line pressures lower than 20 PSI or higher than 105 PSI is not covered by warranty.

7. Water supply 3/8" O.D. unplated copper tube. Waste 1-1/2" IPS. Contractor to supply waste trap and service stop valve in accordance with local code.
8. Connecting lines to be made of unplated copper and should be thoroughly flushed to remove all foreign matter before being connected to fountain. This fountain is manufactured in such a manner that it does not in any way cause taste, odor, color, or sediment problems.
9. Connect fountain to supply line with a shut-off valve and install a 3/8" unplated copper water line between the valve and the fountain. Remove any burrs from outside of water line. Push the tubes straight into the fittings until they reach a positive stop, approximately 3/4" (See Fig. 2). **DO NOT SOLDER TUBES INSERTED INTO THE STRAINER AS DAMAGE TO THE O-RINGS MAY RESULT.**
10. **WINTER :** Remember to winterize your fountain during month where ground freeze may occur.

WARRANTY

The Manufacturer warrants that its products are free from defects in material or workmanship under normal use and service for a period of one year from date of shipment from the factory. The Manufacturer's liability under this warranty shall be discharged solely by repair or replacement of defective material, provided the Manufacturer is notified in writing within the time periods described above. Images must be submitted to evaluate condition of product.

This warranty does not cover installation or labor charges and does not apply to materials, which have been damaged by other causes such as mishandling or improper care or abnormal use. The repair or replacement of the defective materials shall constitute the sole remedy of the Buyer and the sole remedy of the Manufacturer under this warranty. The Manufacturer shall not be liable under any circumstances for incidental, consequential or direct charges caused by defects in the materials, or any delay in the repair or replacement thereof. This warranty is in lieu of all other warranties expressed or implied. Product maintenance instructions are issued with each unit and disregard or non-compliance with these instructions will constitute an abnormal use condition and void the warranty. Stainless steel must be protected on jobsite during construction and must be properly maintained after the water has been introduced into the water cooler or drinking fountain, or the Manufacturer's limited warranty is void.

LIMITED WARRANTY – UNITED STATES & CANADA

LIMITED EXPORT WARRANTY – One year on parts only.

Gyms For Dogs™ - Cool Dog™ Doggie Demand™ products, designs, color schemes, and specifications are exclusive and proprietary as offered. All Rights Reserved. Please contact company if interested in product distribution.



www.CoolDogWaterFountains.com
800-931-1562



ALSO AVAILABLE FROM
COOL DOG™
WATER FOUNTAINS.COM

POWDER COATED STAINLESS STEEL BOWLS

DL-SDB-PRM

The Dog Park Company's Stainless Steel Bowls are painted with a powder coated finish and feature a non-skid ring on the base to keep bowls in place. Featuring bright colors to add a splash of fun to your park or play areas. Holds approximately 24 oz. Choose from Red, Orange, Yellow, or White. **Size: 9.75" dia x 2.5" H Capacity: 24 oz Weight: 3 lbs**



DOG BONE BOWL

DL-BDB-CRT

Great for public parks, the Dog Bone Bowls are finished with a clear coat to protect the bone's finish and to hold up to heavy outdoor use. This fun, doggie-themed product will add an attractive feature to your park, backyard, or play areas. Hand wash only with gentle soap. Heavy with slow drain hole to ensure fresh water. Sits over the trench drain for proper drainage.

Size: 20" L x 7" W x 6.5" H Capacity: 34 oz Weight: 39 lbs

